

UFPR Microgrid: A Benchmark for Distributed Generation and Energy Efficiency Research

Gustavo H. C. Oliveira¹, Roman Kuiava¹, Gideon V. Leandro¹, João A. Vilela Jr.¹,
Rogers Demonti¹, Eduardo P. Ribeiro¹, João S. Dias¹, Elis M. S. Castro¹, André Pedretti²

¹Universidade Federal do Paraná, ²Copel DIS S.A
Curitiba, PR - Brazil

Abstract—This paper introduces the setup of a Distributed Generation Microgrid (DGM) focused onto research on monitoring (electrical and environmental), controlling and operating microgrids. This network is located at the Polytech Center Campus of the Federal University of Paraná (UFPR), in Curitiba, Brazil. It consists of nine 13.8 kV feeders, three Distributed Generation (DG) sources and is connected to the main utility through a 69 kV distribution substation of the state electricity company named as Copel DIS. In addition to the electrical configuration, all components of the microgrid are presented, such as power generation, electrical and environmental meters, μ PMU and the system monitoring computing environment.

I. INTRODUCTION

The advances in the generation of electricity, through the increasing of Renewables Energy Resources (RES), e.g. solar and wind, in the distribution network, have led challenges for stability, control, reliability, operation, power quality, for both renewable energy generation and the distribution or transmission system to which it is connected [1]. Most of these challenges are due to the intermittent nature of most types of Renewable Energy Sources (RES). Fluctuations in power generated by photovoltaic panels due to weather variations may, for example, lead to voltage and frequency fluctuations at the Point of Interconnection (POI) with the distribution system. Such voltage fluctuations may harm power quality, system stability and may require reactive compensation or power support via a Energy Storage System (ESS).

In addition to the challenges for local operation, it is important to carry out studies that assess the possible impacts on the operation of distribution and transmission systems, at the POI or in the rest of the electrical network. From an electrical system perspective, as defined in [1], a microgrid is defined as a group of Distributed Energy Resources (DER), including RES and ESS, plus loads that operate locally as a single controllable entity [2], [3]. It can also be seen as a DG that has a strong component of non-inertial generation but also of generation based on rotating machines. Thus, dynamics of both electromagnetic (associated with photovoltaic generators) and electromechanical (associated with rotary generators) nature will manifest themselves in the grid, requiring the improvement of the measurement capacity of signals of interest (such as voltage and frequency), processing techniques of signals to identify these dynamics of different natures. The improvements on the control methods for the inverters used in photovoltaic generation, fuel cells and ESS are also required.

The evaluation of these dynamics and the understanding of how they interact with each other are very useful for the elaborating operating strategies of the generating and of the accumulating units present in the microgrid, aiming, for instance, the increase of the energy efficiency of the network and improvement of the quality of the energy delivered to consumers.

Other aspects that are also taken into account for the efficient and environmentally proper operation of a microgrid with hybrid power generation are: implementation of an operation center and monitoring of the microgrid, architectural design for the installation of photovoltaic panels based on different technologies, that enable the maximization of the production of electricity throughout the day by properly controlling the emissions of fuel combustion gases to minimize the level of environmental contamination caused by emissions.

Efforts in microgrid development and understanding are being made around the world, such as in works [4] to [12]. In fact, microgrids have been gaining prominence in the urban environment due to the diversification of distributed energy resource types, given the extreme economic competitiveness of alternative or renewable generation sources [13], and the recent increasing availability of economically competitive energy accumulation types [14]. These are local power grids, which can be disconnected from the central system, and often rely on batteries and other storage elements. It is a strong motivator for the growth of microgrids, a combination of distributed energy resources with energy storage systems [15].

In addition to solar and wind power generation, there has been a demand for new alternative sources of power generation, such as power generation from biodiesel, fuel-cell fueled hydrogen and the use of urban and rural solid waste (e.g. biomass, agroforestry waste, plastic packaging, hospital waste, organic sludge and compost waste, among others). This growth, especially in rural areas, makes the study of the dynamics of the electricity system with renewable and distributed sources very important for the agricultural sector.

In this paper, the current stage of development of a distributed generation microgrid, focused on research on monitoring (electrical and environmental), control and performance of the electrical system is presented. This microgrid is located at the Polytech Center Campus of the Federal University of Paraná (UFPR) in Curitiba, Brazil. It consists of nine 13.8 kV feeders and its POI is connected to a 69 kV substation of the

state energy distribution utility by a 5 km long feeder.

The DG included in this microgrid consists of two photovoltaic (PV) solar generation plants and a synchronous biodiesel generator. The first PV solar generation plant has an installed power of about 1100 kWp and the second one about 110 kWp. Among these, the smaller plant, together with electrical accumulation devices present in it, will form a micro network that will enable advanced studies of control systems for operation in both connected and islanded modes. Finally, the network also has a 50 kW biodiesel-powered synchronous thermal turbine generator.

Not least, it should be noted that that electrical and climate data are being concentrated in a monitoring center, which is able to provide real-time information on system operation and control. This monitoring center represents a database for studies and actions to develop new operation for the distribution system, identification of business opportunities for consumers and dealers, as well as energy efficiency at this university campus.

The article is structured as follows. In Section 2, there is a description of the distributed generation microgrid. Section 3 describes the microgrid implemented within the main microgrid. In Section 4, the electrical and weather data monitoring center, including the μ PMUs network included in the microgrid, is presented. Section 5 discusses some energy efficiency actions related to the microgrid. Finally, in Section 7, the article is completed.

II. UFPR MICROGRID

A. Description

The UFPR Polytech Center campus microgrid network, located in the city of Curitiba/PR, Brazil, consists of 9 feeders (comprising approximately 3 km of underground cables) at 13.8 kV connected to campus consumers through 16 transformers 13.8/0.220 kV in the Δ -Y configuration. Total load is about 1.75 kVA. The microgrid POI (bus 5) is connected to the state energy distribution utility (COPEL-DIS, Companhia Paranaense de Energia) through a approximately 5 km long 13.8 kV distribution feeder (named as Prado), to a 69 kV Substation (Capanema Substation). Figure 1 shows the single-line diagram of the system under study. In Figure 1, one can see the two PV solar plants at bus 16 and 23, and the synchronous biodiesel generator at bus 26. Both PV solar plants are being constructed and will be operating up to november 2019. The map of the campus is depicted at Figure 2, see also GPS location 25.4508S, 49.2312W.

B. PV Solar Plants

Two PV plants are being deployed at the UFPR Polytech Campus. The former (named PV-BIO plant), with an approximately installed power of 1100 kWp, is being placed in the Biological Sciences Sector parking lot and will be connected to bus 16 of the single-line diagram of Figure 1. The location can be viewed in blue on Figure 2 and a predicted aerial view is depicted in Figure 3. Near the top of these figures, it's possible to see the building of the UFPR Biological Sciences Sector

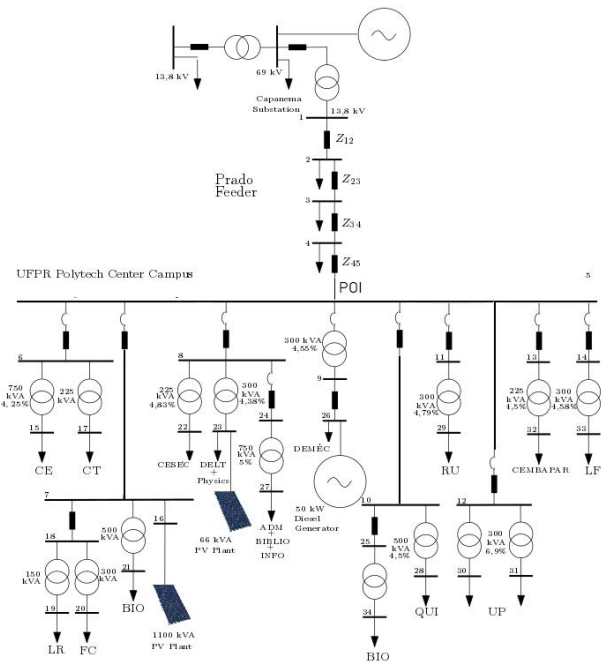

Fig. 1. Single-line diagram of the UFPR Campus Microgrid.

and, on the right, over the parking lot, the future installations of the PV plant. This FV-BIO plant will feature a 1800kVA 13.8/0.480kV transformer, 7 (seven) 175 kW DC/AC drives, powered by 273 PV modules, 400Wp each.

The latter (named PV-DELT plant), with 110 kWp of installed power, will be located in the Department of Electrical Engineering (DELT) and will be connected to Bus-23 of the single-line diagram in Figure 1.

III. DELT MICROGRID

Inside the UFPR Microgrid, one can find a smaller microgrid, named DELT Microgrid, which can allow the isolated mode operation of the Department of Electrical Engineering since it is provided by a PV solar plant (PV-DELT) and BESS devices.

The location of this microgrid is depicted at bus 23 in Figure 1 and in Figure 2, highlighted in blue in the center of the figure. Figure 4 describes the main devices at this microgrid, including the energy storage equipments and priority loads, which can be disconnected from the medium voltage network by the switch shown at the top of the figure. In this figure, it can be noticed the presence of three sets of PV sources: 3.5 kWp connected to a 220V AC network; 10 kWp connected to a 725V DC network and 95 kWp connected to a 400 V AC network included in the DELT Microgrid. As it can be seen in Figure 4, the microgrid has 3 storage technologies for comparative studies of the electrical system with different charge/discharge cycles, different life and power density.

The architecture of the microgrid provides that, in case of lack of distribution network or control decision, it can operate autonomously. Through the storage elements (lithium

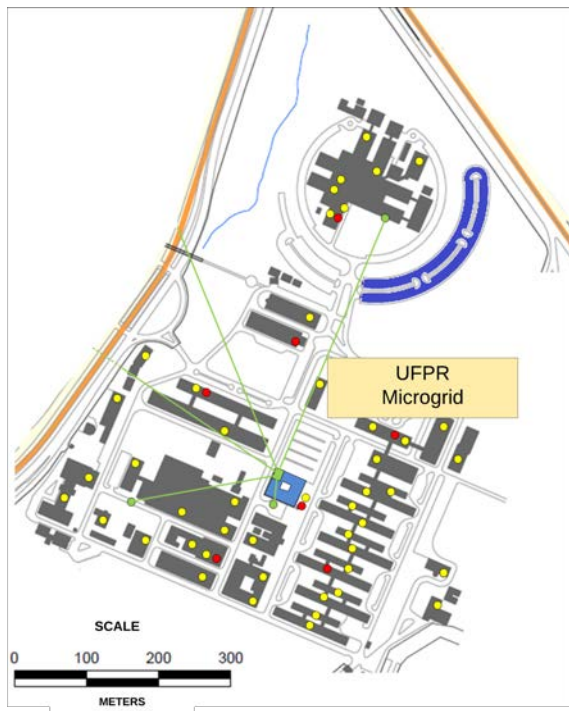

Fig. 2. Map of the the UFPR Campus Microgrid.



Fig. 3. PV-Plant

and sodium nickel battery banks), the DC-DC converters and the DC-AC converter, this microgrid can store energy and operate isolated from the rest of the UFPR microgrid. The two storage elements together provide a power capacity of 55 kWh and 1 C rated power of 22.5kW. When reconnecting the rest of the network, the supervision and control system (Control Center) acts on the effective values, frequency and phase of the internal voltage of the main bus, allowing reconnecting without

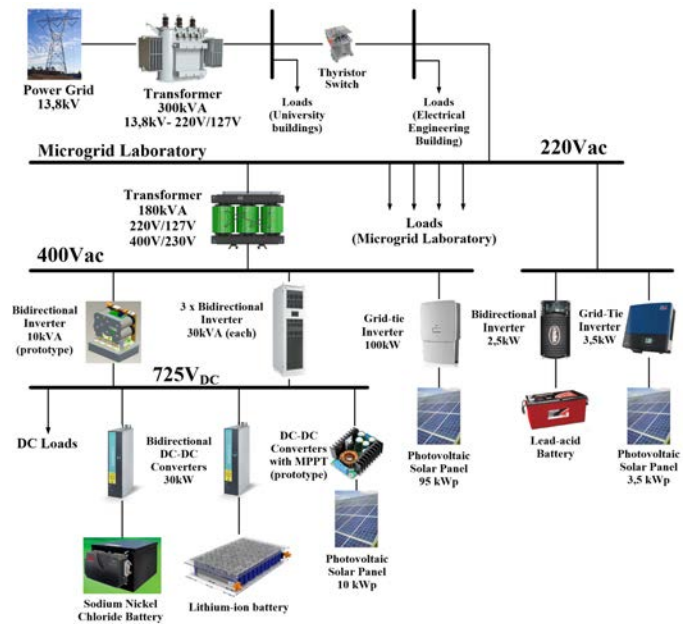

Fig. 4. Microgrid with buses, storage elements, loads and interrupting elements.

shutdown. Practical studies of island network control systems design as well as reconnecting techniques will be carried out.

The supervision and control system consists of a server with modbus TCP communication protocol, with SCADA supervisory control. Devices are connected with ethernet interface (native or with converter) in a dedicated virtual local area network (VLAN). As photovoltaic inverters allow control of reactive energy [17] within the nominal apparent power limits (0 to 1, inductive and capacitive), the supervision and control system will also act to control the overall power factor of the microgrid. With the aid of the DC-AC converter, whose power factor can be adjusted from 0.6 to 1 (inductive and capacitive), the microgrid can also optimally produce reactive energy for the DELT microgrid in order to improve the local voltage profile. Practical studies of design of voltage control systems of networks with DG and intermittent sources will be carried out.

IV. OPERATION AND MONITORING CENTER: METERS, PMU NETWORK AND METEOROLOGICAL DATA

An Operation and Monitoring Center (OMC) was designed and built on the Polytech Center Microgrid. The OMC is located in the Distributed Generation Laboratory which, in turn, is located in the Department of Electrical Engineering of UFPR, as highlighted in blue in the center of Figure 2.

The OMC is responsible for receiving, storing and making available the electrical data for viewing and analysis in real-time or from the records. The control panel has three monitors for viewing and monitoring the various available signals. Part of the data are available in internet.

Data processing and storage is performed by servers with redundant power supplies, multiple hard drives that allow mirroring (RAID 1) and hot swap on failure, and multiple processors. The adopted operating system is based on free software (Debian 9.0) and the physical machine runs several virtual machines. On this way it is possible to have multiple processing in isolation and safety.

Regarding electrical data for real-time monitoring, they come from three different types of measurement equipment: 89 power meters, 6 energy quality analyzers and 6 Micro Phasor Measurement Units (μ PMUs).

Due to the presence of two photovoltaic (PV) solar generation plants, the project counts with a meteorological data monitoring station. These information, detailed in Section IV-C, is also incorporated into the OMC. The μ PMU network is also described in Section IV-B.

All data from the monitoring system is captured and taken over the network to the OMC to be saved for offline studies and used for real-time operational decision making. Among the possible studies related to the integration of renewable sources in the electrical system, the analysis of energy quality, dynamic performance and state estimation may be highlighted. The detection of transient signatures and aspects of communication and data traffic is also noteworthy. The meteorological data monitoring station supports energy efficiency studies in various aspects such as power generation from PV solar generation plants, module degradation and also contributes to the compilation of a historical data sets for future studies.

Figure 5 illustrates a connection diagram of the OMC. Some μ PMUs are connected directly to the monitoring center. Other μ PMUs and measurement equipments are physically connected to the university's existing network infrastructure and may participate in the dedicated monitoring VLAN or simply transmit data from a dedicated IP address. Outside university PMUs transmit data over the internet with the UDP protocol. Virtual Private Network (VPN) is planned for some critical control devices, such as inverter control actions.

A. Software Structure

Many softwares can be used for processing, storing and visualizing data of electrical quantities. In the microgrid, openPDC software (open source PMU data concentrator or open source μ PMU data concentrator) is being used, which receives the phasors from μ PMU and stores them and can also be passed on to other software or concentrators. The encapsulation and data transfer standard used is IEEE Std C37.118.2-2011.

The monitoring center also uses free software for the Supervisory Data Acquisition and Control/Energy Management System (SCADA/EMS) function.

The web energy monitoring Content Management System (CMS) has been adapted for the storage and monitoring of signals from μ PMUs at two points. The first concerns the sample rate and storage. The Emoncms System 17 typically stores low frequency meter data, typically one every minute, with a minimum storage period of 1 second. The system has

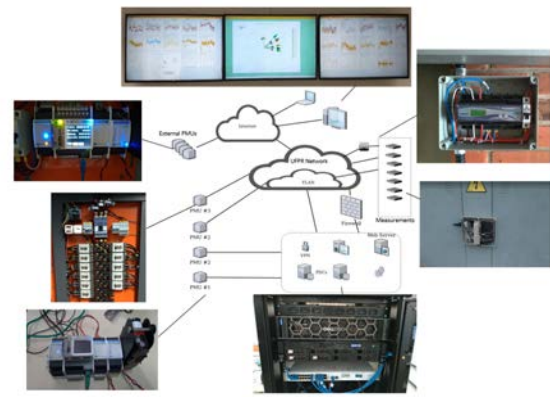

Fig. 5. Operation and Monitoring Center Connection Diagram

been modified to a minimum period of 1 ms to accommodate data sent by μ PMUs that have a sampling rate of 8.33 ms (or 120 phasors/second). A dedicated code (scripted in Python) was created for the constant reception of phasors from μ PMUs for storing directly to the database, in order not to overload the processing that is natively based on the HTTP protocol.

The second modification made concerns the preprocessing of the phasors (Python code) which aimed to interpret them as a positive phase sequence (clockwise progression). This was aimed at comparing stored data with phasor data from third-party PMUs.

B. PMU Network

As shown in Section IV, the microgrid has 3 μ PMU units [19] (other 3 units are located outside the Polytech Center Campus) and is configured to connect to other PMU networks. The μ PMUs provide ultra-precise measurements of magnitudes (on the order of 10^{-4} pu) and phase angles (on the order of 0.01°) of voltages (or synchrophasors). The μ PMU locations are illustrated in Figure 6 (a). This figure shows the presence of 4 units in the city of Curitiba, all located in state energy distribution utility (COPEL-DIS, Companhia Paranaense de Energia) distribution network. Three of them are in the Polytech Center Campus, specifically at buses 16 (one unit) and 23 (two units) (see Figure 1), and one unit in another UFPR campus, the Agrarias Campus. Other two μ PMUs are being installed in the cities of Palotina (on another campus of UFPR) and Faxinal (in a substation of COPEL), also in the state of Paran. Figure 6 (b) shows images of two μ PMUs installed on the Polytech Center Campus and UFPR Agrarias Campus. The μ PMUs installed in the distribution grid may be used to monitor the dynamic behavior of the grid itself due, for example, to the entry and exit of PV solar generation plants at the UFPR Polytech Center Campus.

C. Climate Data

Due to the presence of PV generation plants, the microgrid has a meteorological data monitoring station, which directly and indirectly affects power generation. Thus, horizontal and inclined solar radiation, air and PV module temperature, air

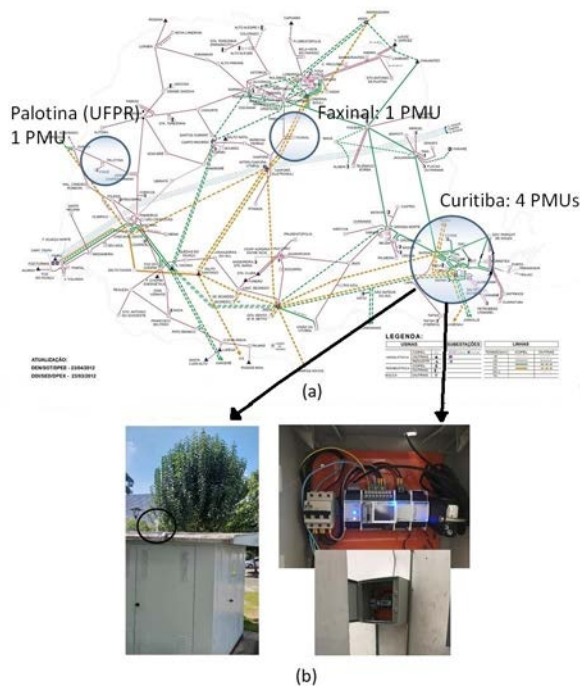

Fig. 6. Monitoring Center μ PMU network. (a) Transmission system of COPEL in Parana state and the location of the μ PMUs. (b) Images of two μ PMUs, one located at the Polytech Center Campus (left) and the other one at Agrarias Campus (right).

humidity and PV modules, wind speed and direction, incident ultraviolet radiation and rainfall are measured.

One of the main sensors present in the weather data monitoring station a Pyranometer capable of measuring direct solar radiation, in the horizontal or inclined plane, which is directly associated with the energy production of PV generation plants. The models used (are two sensors) have standard secondary accuracy class, with a measurement range from 0 to 4,000 W/m^2 and a spectral range from 285 nm to 3000 nm. Furthermore, the equipment has a heating system that provides temperature compensation in sensor measurements.

V. ENERGY EFFICIENCY ACTIONS

A commission for the planning and control of electricity consumption, part of UFPR's Energy Management System, has been created and is consolidating monitoring and energy consumption metrics that will be integrated with the indicators obtained from the energy meters and power quality. In this way, it will be possible to obtain the situation of consumption in real time and make decisions, as well as define policies to stimulate the efficient consumption of energy with the university community. In this work, is being incorporated the process of building certification according to National Electricity Conservation Program and Energy Management System - ISO 50.001.

VI. CONCLUSION

In this paper, the characteristics of the UFPR Microgrid aimed at research on stability, monitoring, control and ef-

iciency of electrical microgrids have been presented. All detailed have been presented, including PV-based DG, BESS, communication/ monitoring, control, measurement devices. The purpose of the microgrid is to be a practical benchmark for research in the area of connecting DG with renewable sources in the distributor's medium voltage network.

ACKNOWLEDGMENT

This research was supported by the Companhia Paranaense de Energia COPEL research and technological development program, through the PD 02866-0470/2017 project, regulated by ANEEL.

REFERENCES

- [1] Canizares, C. A.; Reilly, J. and IEEE-PES Task force. Microgrid Stability Definitions, Analysis and Examples. IEEE Transactions on Power Systems, April, p. 1-17, 2019.
- [2] Lasseter, B. Microgrids [distributed power generation]. IEEE Power Engineering Society Winter Meeting, 2001.
- [3] Olivares, D. E., et al. Trends in Microgrid Control IEEE Transactions on Smart Grid. vol. 5, n. 4, 2014.
- [4] Khadkikar, V.; Kirtley, J. L. Interline Photovoltaic (I-Pv) Power System A Novel Concept Of Power Flow Control And Management. IEEE Power And Energy Society General Meeting. 2011
- [5] Kouro, S. Et Al. Grid-Connected Photovoltaic Systems: An Overview Of Recent Research And Emerging Pv Converter Technology. IEEE Industrial Electronics Magazine, V. 9, N. 1, P. 4761, March 2015.
- [6] Liu, S.; Liu, P. X.; Wang, X. Stochastic Small-Signal Stability Analysis Of Grid-Connected Photovoltaic Systems. IEEE Transactions On Industrial Electronics, V. 63, N. 2, P. 10271038, Feb 2016
- [7] Moradi-Shahrbabak, Z.; Tabesh, A. Effects Of Front-End Converter And De-Link Of A Utility-Scale Pv Energy System On Dynamic Stability Of A Power System. IEEE Transactions On Industrial Electronics, V. 65, N. 1, P. 403411, 2018.
- [8] Ningbo, W. The Key Technology Of The Control System Of Wind Farm And Photovoltaic Power Plant Cluster. International Conference On Power System Technology. 2014. P. 28332839.
- [9] Romero-Cadaval, E. Et Al. Grid-Connected Photovoltaic Plants: An Alternative Energy Source, Replacing Conventional Sources. IEEE Industrial Electronics Magazine, V. 9, N. 1, P. 1832, March 2015.
- [10] Shayanfar, H. A.; Malek, S. Photovoltaic Microgrids Control By The Cooperative Control Of Multi-Agent Systems. 30th International Power System Conference (Psc). 2015. P. 287293.
- [11] Varma, R. K.; Salehi, R. Ssr Mitigation With A New Control Of Pv Solar Farm As Statcom (Pv-Statcom). IEEE Transactions On Sustainable Energy, V. 8, N. 4, P. 14731483, Oct 2017.
- [12] Zhang, X.; Yang, L.; Zhu, X. Integrated Control Of Photovoltaic-Energy Storage System For Power Oscillation Damping Enhancement. IEEE 8th International Power Electronics And Motion Control Conference (Ipem-Ecce Asia). 2016.
- [13] Levelized Cost and Levelized Avoided Cost of New Generation Resources in the Annual Energy Outlook 2019. Independent Statistics & Analysis. U.S. Energy Information Administration. Feb, 2019
- [14] Ran Fu, Timothy Remo, and Robert Margolis. 2018 U.S. Utility-Scale PhotovoltaicsPlus-Energy Storage System Costs Benchmark. Technical Report NREL/TP-6A20-71714 November 2018
- [15] EPRI Technical Report. Program on Technology Innovation: Microgrid Implementations: Literature Review, 2016
- [16] F.H.M. Rafi, M. J. Houssain, D. Leskarac, J. Lu. Reactive Power Management Of A Ac/Dc Microgrid System Using A Smart Pv Inverter. Power & Energy Society General Meeting, 2015.
- [17] Grid Protection Alliance, Openpdc Software, [https://github.com/ Grid-protectionalliance/Openpdc](https://github.com/Grid-protectionalliance/Openpdc), 2018.
- [18] Openenergymonitor Project, Emoncms, <https://github.com/Emoncms/Emoncms>, 2018.
- [19] A. Von Meier, E. Stewart, A. Mceachern, M. Andersen And L. Mehrmanesh, Precision Micro-Synchrophasors For Distribution Systems: A Summary Of Applications. IEEE Transactions On Smart Grid, Vol. 8, No. 6, Pp. 2926-2936, Nov. 2017.